

# Carts & Kiosks - Merchandising Carts

Contact Your Vollrath Sales Representative for Custom Carts & Kiosks!

Carts & Kiosks—Merchandising Carts

**Option:** Signage for ACM wrap-style and tubular canopy.  
Vinyl graphics on ACM (artwork provided by customer)

**Standard:** Polyform or laminate countertop (laminate color must be specified)

**Option:** 1" (2.5cm) bumper (all sides)

**Standard:** All aluminum composite material construction  
-Standard black or silver (specify)  
-Matching toe kick

**Standard:** Heavy-duty casters

**Option:** ACM wrap-style canopy with two adjustable poles (color matching base)

**Option:** Base color option  
-laminate (one color) on 3 sides  
-painted base (one color) on 3 sides  
-digital graphics (artwork supplied by customer) on 3 sides

**Option:** Track lighting for canopies (Requires at least 120V 15 AMP service)  
-15 amp 120V electrical service (NEMA 5-15P)  
-20 amp 120V electrical service (NEMA 5-20P)  
-30 amp electrical service (NEMA #L14-30P)  
-60 amp electrical service (plug #460P-12W)  
-100 amp electrical service (plug#4100P-12W)

**Option:** Heavy duty paddle latch doors (qty. 2 for 6', qty. 5 for 8', qty. 6 for 10')

Back view - Item 75675 shown with modular options

**Option:** Countertop grommet holes

Item 75675

**Standard Feature** (Not Shown)

- Open storage (server side)

**Optional Features** (Not Shown)

- Adjustable undercounter shelving
- Umbrella

- Aluminum tubular canopy (bulkhead) with two adjustable poles (powder coated - color specified)



Setting the Standard™

# Carts & Kiosks - Merchandising Carts

Merchandising Carts — Dimensions shown in IN (CM)

75674

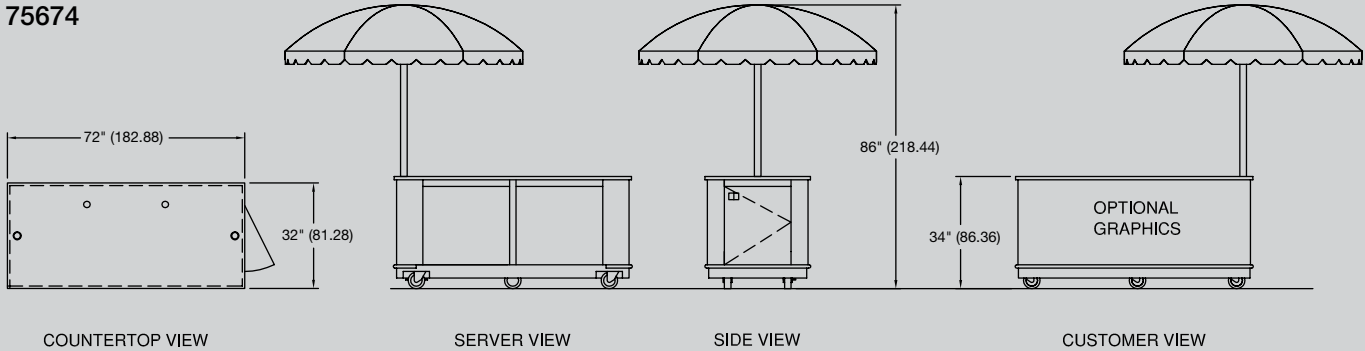

75690

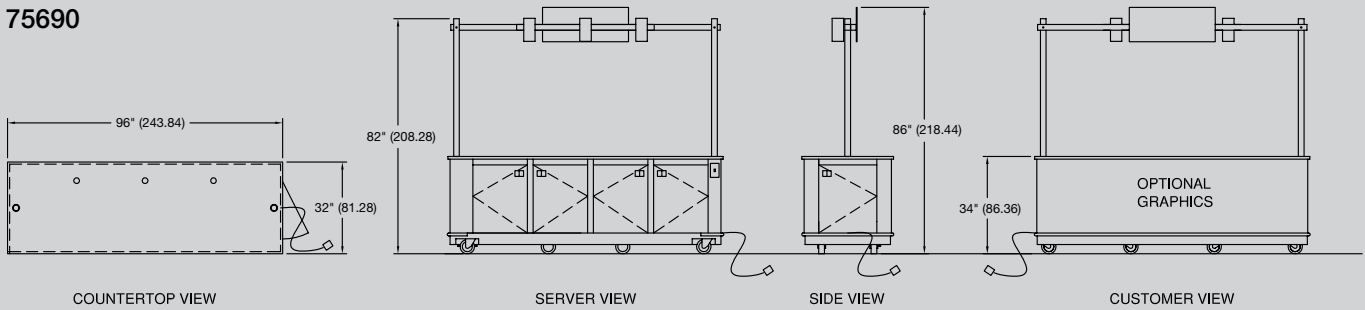

75675

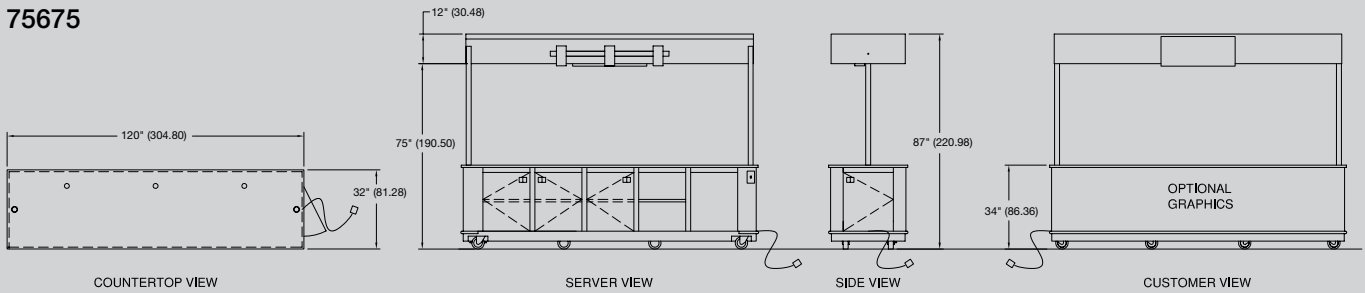

Receptacles



The Vollrath Company, L.L.C.  
1236 North 18th Street  
Sheboygan, WI 53081-3201 USA  
Customer Service: 800.628.0830  
Equipment Service: 800.628.0832  
Main PH: 920.457.4851  
Fax: 920.459.6573  
Form L35704 Rev 4/09



Setting  
the Standard™