

**FRYERS****VULCAN****ER KLEENSCREEN PLUS® FILTRATION SYSTEM  
BUILT-IN FILTRATION SYSTEM FOR 1ERF FRYERS****Model 1ER50CF**

Shown with optional castor accessory

**SPECIFICATIONS**

Built-in filter system, Vulcan-Hart Model No.1ER (lb. capacity 50 or 85) (control type A, D, or C) F (add suffix -F to fryer battery Model No., i.e. 1ER50DF). Filter system accommodates one 50 lbs. or one 85 lbs. fryer. 1/3 H.P. motor and pump circulates hot frying compound at the rate of 8 gallons per minute, activated by a one touch push button switch. System provided standard with paperless stainless steel mesh filter screen. Optional KleenScreen PLUS® envelopes filter out particulate down to .5 microns (trial package included). Standard equipment comes on legs, has a tank brush and clean-out rod. Hands free oil return line connection. Drain valve interlock switch turns fryer's heating elements off when drain valve is opened. Power supply is 208 volt, 60 Hz, 3 phase.

UL Listed. NSF Listed.

**STANDARD FEATURES**

- Filter system accommodates 1ER50F or 1ER85F.
- Choose from Solid State Analog Knob Control (A), Solid State Digital (D) or Computer (C) Controls.
- Boil Out ByPass™ easily removes boil out solution from fry tank without contact of drain manifold, filter pan or motor/pump.
- Drain valve interlock switch (DVI) shuts off heating elements when drain valve is opened.
- 18 gauge stainless steel filter pan. 65 lbs. frying compound capacity on 1ER50F, 100 lbs. capacity on 1ER85F.
- 6" adjustable legs.
- Paperless stainless steel 2 sided filter area; 1ER50F = 220 sq. inches; 1ER85F = 462 sq. inches. Microfiltration Fabric Envelope filters out particulate down to .5 microns.
- 1/3 H.P. motor and pump circulates frying compound at a rate of 8.0 gallons per minute.
- 4' high temperature discard hose.
- One touch push button switch to engage pump and motor (solid state controls).
- Tank brush and clean-out rod.
- One year limited parts and labor warranty.
- 10 year limited fry tank warranty.

**ACCESSORIES (Packaged & Sold Separately)**

- Stainless steel tank cover – doubles as a work surface top.
- Micro-Filtration Fabric Envelopes – 6 filters/per package.
- Casters, adjustable (2 locking, 2 non-locking).
- "Add-On" Frymate™ – VX15S or VX21S.
- Prison Security Package (Factory Installed).
- Single Basket Lift (Factory Installed).
- 10" high stainless steel splash guard.

**OPTIONS**

- 480 volt, 3 phase (NEMA 5-15P). (Separate 120 volt, 20 amp electric supply required.)
- Second year extended limited parts and labor warranty.

**REFERENCE MATERIALS**

- See 1ER50 Spec Sheet F32900 for electrical specs.
- See 1ER85 Spec Sheet F32901 for electrical specs.
- See ERF Spec Sheet F32456 for electric fryer batteries.

**VULCAN**

a division of ITW Food Equipment Group LLC

P.O. Box 696 ■ Louisville, KY 40201 ■ Toll-free: 1-800-814-2028 ■ Local: 502-778-2791 ■ Quote &amp; Order Fax: 1-800-444-0602



**ER KLEENSCREEN PLUS® FILTRATION SYSTEM  
BUILT-IN FILTRATION SYSTEM FOR 1ERF FRYERS**

**INSTALLATION INSTRUCTIONS**

1. A combination valve with pressure regulator is provided with this unit. Natural Gas 4.0" (102 mm) W.C. Propane Gas 10.0" (254 mm) W.C.
2. An adequate ventilation system is required for Commercial Cooking Equipment. Information may be obtained by writing to the National Fire Protection Association, Batterymarch Park, Quincy, MA 02269. When writing refer to NFPA No. 96.
3. All models require a 6" (152 mm) clearance at both sides and rear adjacent to combustible construction.
4. All models require a 16" (407 mm) minimum clearance to adjacent open top burner units.

5. This appliance is manufactured for commercial installation only and is not intended for home use.

**SERVICE CONNECTIONS:**

- Ⓔ 480 volt ER KleenScreen PLUS® require a separate 120V (NEMA 5-15P), 60 Hz, 1 phase electrical power connection to operate the filter motor/ pump and digital controls, (not supplied with the fryer).

**NOTE:** In line with its policy to continually improve its product, Vulcan reserves the right to change materials and specifications without notice.

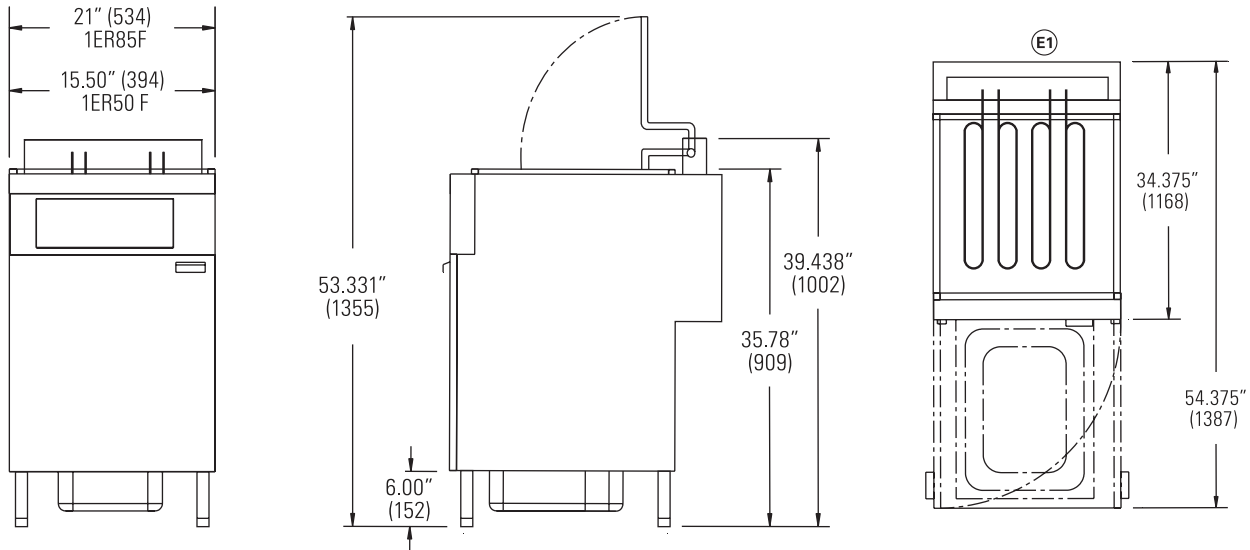

**FILTRATION SYSTEM SPECIFICATIONS**

Model	Filter Pan Capacity	Filter Area		Motor / Pump			
		Screen	Micro-Filtration Fabric Envelope	H. P.	RPM	Gal. / Min.	Electrical
1ER50F	65 lbs.	220 sq. in.	225 sq. in.	1/3 H.P.	1750 RPM	8.0 Gal./min.	<b>208V Units:</b> 208V 3.6A 50/60Hz 1Ph
							<b>408V Units:</b> 120V 5.0A 50/60Hz 1Ph
1ER85F	100 lbs.	462 sq. in.	515 sq. in.	1/3 H.P.	1750 RPM	8.0 Gal./min.	<b>208V Units:</b> 208V 3.6A 50/60Hz 1Ph
							<b>408V Units:</b> 120V 5.0A 50/60Hz 1Ph

**FRYER SPECIFICATIONS:**

- **1ER50 (17 Kw)** – See Spec Sheet F32900
- **1ER85 (24 Kw)** – See Spec Sheet F32901

**Note:** Add 5 Amps for the motor / pump

This appliance is manufactured for commercial use only and is not intended for home use.



a division of ITW Food Equipment Group LLC

P.O. Box 696 ■ Louisville, KY 40201 ■ Toll-free: 1-800-814-2028 ■ Local: 502-778-2791 ■ Quote & Order Fax: 1-800-444-0602