

**HOLDING & TRANSPORT****VULCAN****VHP15  
HOLDING & TRANSPORT CABINET**

Model VHP15

 **VHP15** Holding & Transport Cabinet**STANDARD FEATURES**

- Holding and Transport Capacity  
Narrow footprint designed specifically to hold 15 each 12" x 20" x 2½" pans on fixed racking
- Blower motor for gentle and even temperature distribution
- 5" heavy duty casters (2 swivel with brakes and 2 rigid)
- Recessed side mounted push/pull handles
- Dutch doors
- Recessed control panel
- Dual indicator lights
- Thermometer
- Full range thermostat for temperatures up to 190°F (88°C)
- Interior and exterior are both constructed out of 20 gauge stainless steel
- Fully insulated with 1½" in side walls and 2" in top
- Integrated steel frame for maximum strength
- Magnetic action door latches
- Field reversible doors
- Lifetime warranty on heating elements
- Top mounted cord
- Cord wrap
- Complete with cord and plug: NEMA 5-15 for 120 volts and NEMA 6-15 for 208-240 volts
- 120 volts, 1200 watts, 10 amps

**SPECIFICATIONS**

Vulcan Model VHP15 heated holding and transport cabinets with a narrow footprint designed specifically to hold 15 each 12" x 20" x 2½" pans on fixed racking. Blower motor for gentle and even temperature distribution. Comes complete with 5" heavy duty casters (2 swivel with brakes and 2 rigid) and Dutch doors. Recessed control panel containing dual indicator light, thermometer, and full range thermostat for temperatures up to 190°F (88°C). Cabinet interior and exterior are both constructed out of 20 gauge stainless steel. Recessed side-mounted push/pull handles, magnetic action door latch, and full insulation; 1½" in side walls and 2" in top. Integrated steel frame for maximum strength. Field reversible doors. Lifetime warranty on heating elements. Complete with top mounted cord, cord wrap, and plug: NEMA 5-15 for 120 volts and NEMA 6-15 for 208-240 volts. 120 volts, 1200 watts, 10 amps.

UL Listed to Canadian safety standards. Classified by UL to NSF Std. #4

**OPTIONS**

- 208/240 volts
- Humidity pan
- Full perimeter bumper

**VULCAN**

a division of ITW Food Equipment Group LLC

P.O. Box 696 ■ Louisville, KY 40201 ■ Toll-free: 1-800-814-2028 ■ Local: 502-778-2791 ■ Quote &amp; Order Fax: 1-800-444-0602



**VHP15**  
HOLDING & TRANSPORT CABINET

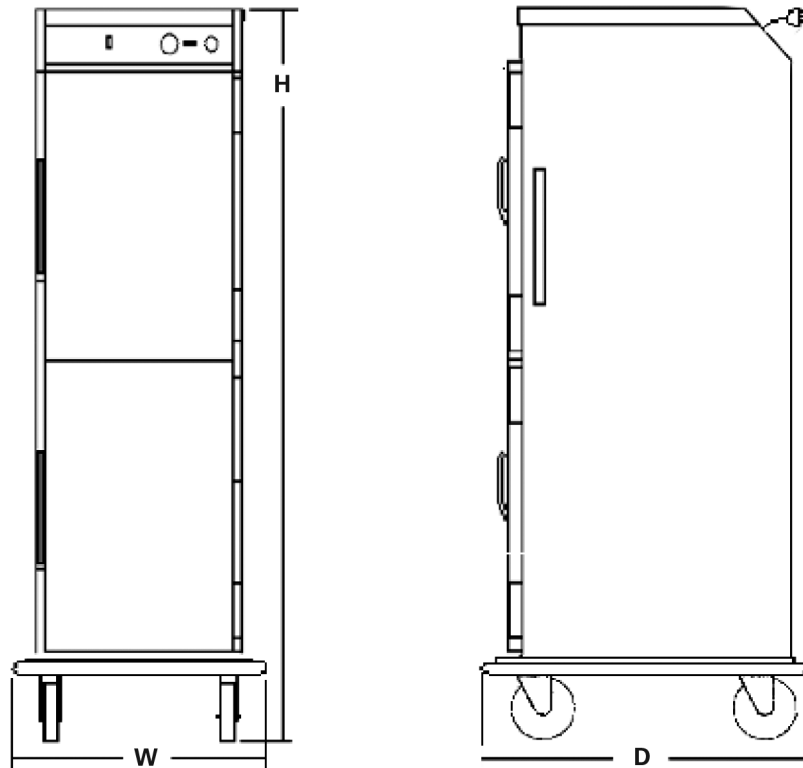
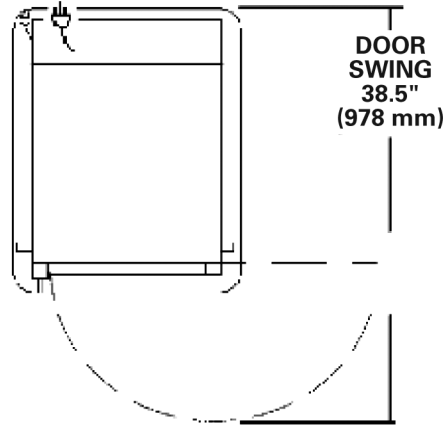

MODEL	CAPACITY 12" x 20" x 2½"	HIGH	DEEP	WIDE	SHIPPING WEIGHT	VOLTS	WATTS	AMPS
VHP15	15	60.5" 1537 mm	26.75" 679 mm	17.25" 438 mm	200 lbs. 91 kg	120	1200	10



a division of ITW Food Equipment Group LLC

P.O. Box 696 ■ Louisville, KY 40201 ■ Toll-free: 1-800-814-2028 ■ Local: 502-778-2791 ■ Quote & Order Fax: 1-800-444-0602