

GRIDDLES & BROILERS**VULCAN****VTEC SERIES
COUNTER MODEL GAS INFRARED CHARBROILER**

Model VTEC48

**SPECIFICATIONS**

High efficiency gas infrared charbroiler, Vulcan Model No. _____. Stainless steel front, sides and top trim. Full width, stainless steel front crumb tray. Heavy duty, steel infrared emitter panels. 11" x 25" stainless steel cooking grids. One 22,000 BTU/hr. patented infrared burner system for each cooking grid. Direct ignition piezo spark igniters. One high range heat control valve for each burner. Chrome burner knobs. 4" adjustable legs. 3/4" NPT rear gas connection and gas pressure regulator.

Exterior Dimensions:

_____ " wide x 35 1/8" deep x 12 1/2" working height.

CSA design certified. NSF listed.

**SPECIFY TYPE OF GAS WHEN ORDERING.
SPECIFY ALTITUDE WHEN ABOVE 2,999 FT.**

- VTEC14** 14 1/2" wide
- VTEC25** 25 1/2" wide
- VTEC36** 36 1/2" wide
- VTEC48** 47 1/2" wide
- VTEC60** 58 1/2" wide

STANDARD FEATURES

- Stainless steel sides, control panel, top trim and backsplash
- Full width, stainless steel front crumb tray
- Heavy duty steel infrared emitter panels
- 11" x 25" stainless steel cooking grids (providing 275 square inches of cooking area in each burner zone)
- Energy efficient 22,000 BTU/hr., patented infrared burner system in each cooking zone
- Direct ignition piezo spark igniters
- One high range heat control valve for each burner
- Chrome burner control knobs
- Removable, stainless steel heat shield and splash guard
- 4" adjustable legs
- 3/4" NPT rear gas connection and gas pressure regulator provided
- One year limited parts and labor warranty

ACCESSORIES

Ordered separately and field installed

- Stainless steel "Fish Grates" with smaller, 1/4" rib spacing.
- Stainless steel stand with undershelf and casters.

VULCAN

a division of ITW Food Equipment Group LLC

P.O. Box 696 ■ Louisville, KY 40201 ■ Toll-free: 1-800-814-2028 ■ Local: 502-778-2791 ■ Quote & Order Fax: 1-800-444-0602



VTEC SERIES
COUNTER MODEL GAS INFRARED CHARBROILER

INSTALLATION REQUIREMENTS:

1. A gas pressure regulator supplied with the unit must be installed:
Natural Gas 4.0" (102 mm) W.C.
Propane Gas 10.0" (254 mm) W.C.
2. An adequate ventilation system is required for commercial cooking equipment. Information may be obtained by writing to the National Fire Protection Association, Batterymarch Park, Quincy, MA 02269. When writing refer to NFPA No. 96.
3. These units are manufactured for installation in accordance with National Fuel Gas Code, ANSI-Z223.1/NFPA #54 (latest edition). Copies may be obtained from The American Gas Association, Accredited Standards Committee Z223 @ 400 N. Capital St. NW,

Washington, DC 20001, or the Secretary Standards Council, NFPA, 1 Batterymarch Park, Quincy, MA 02169-7471.

NOTE: In The Commonwealth of Massachusetts

All gas appliances vented through a ventilation hood or exhaust system equipped with a damper or with a power means of exhaust shall comply with 248 CMR.

4. CLEARANCES

| | |
|-------|-----------------|
| | Non-Combustible |
| Rear | 0" |
| Sides | 0" |

5. This appliance is manufactured for commercial installation only and is not intended for home use.

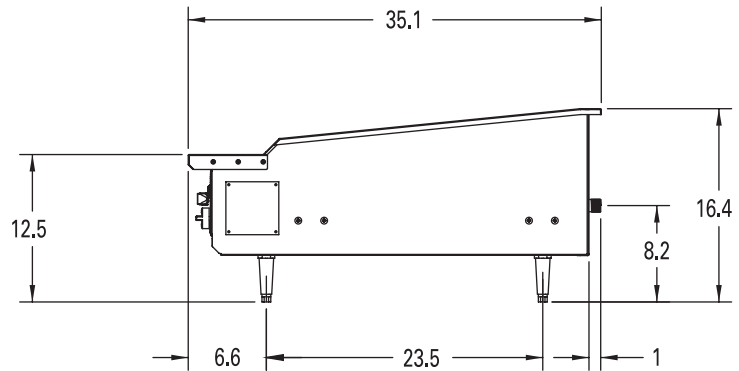
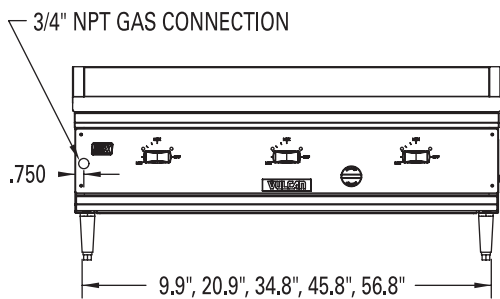
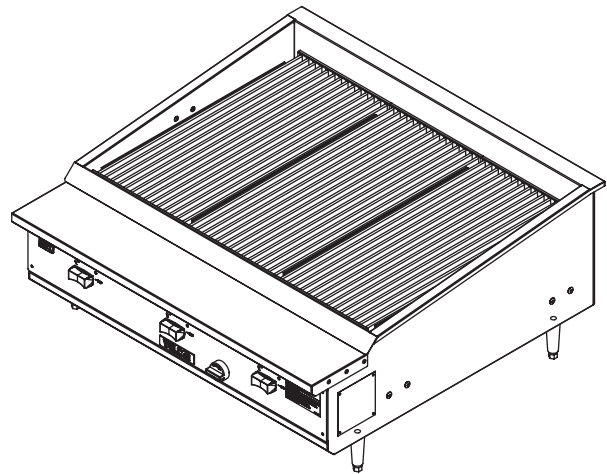
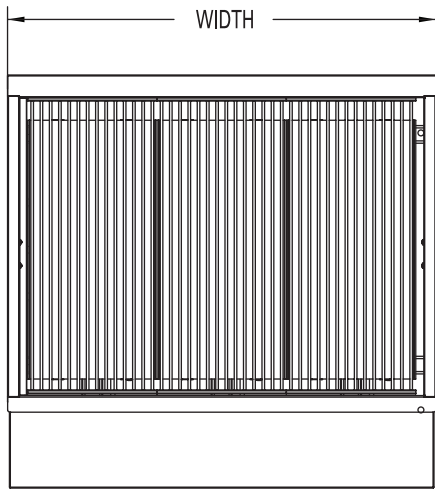

| MODEL | WIDTH | DEPTH | OVERALL HEIGHT | WORKING HEIGHT* | BROILING AREA | # BURNERS | TOTAL BTU/HR | APPROX SHIP WT (LB/KG) |
|--------|-------|-------|----------------|-----------------|---------------|-----------|--------------|------------------------|
| VTEC14 | 14.4" | 35.1" | 16.4" | 12.5" | 11" x 25.25" | 1 | 22,000 | 97/44 |
| VTEC25 | 25.4" | | | | 22" x 25.25" | 2 | 44,000 | 151/68 |
| VTEC36 | 36.4" | | | | 33" x 25.25" | 3 | 66,000 | 210/95 |
| VTEC48 | 47.4" | | | | 44" x 25.25" | 4 | 88,000 | 264/120 |
| VTEC60 | 58.4" | | | | 55" x 25.25" | 5 | 110,000 | 309/140 |



a division of ITW Food Equipment Group LLC

P.O. Box 696 ■ Louisville, KY 40201 ■ Toll-free: 1-800-814-2028 ■ Local: 502-778-2791 ■ Quote & Order Fax: 1-800-444-0602

NOTE: In line with its policy to continually improve its products, Vulcan reserves the right to change materials and specifications without notice.