



Features

- Heavy-duty 1+ HP motor to handle the heaviest mixing tasks
- Large, 7-quart stainless steel bowl with carrying handles
- 12 mixing speeds with soft start for precision mixing
- Pulse function with maximum burst of power
- Tilt-back head for easy removal of attachments
- Full die-cast housing
- Includes chef's whisk, mixing paddle, dough hook and splash guard with feed chute
- Limited Two Year Warranty

Professional 7-Quart Stand Mixer

Accessories include:

- Dough Hook
- Whisk Attachment
- Splash Guard
- Paddle



WSM7Q





Professional 7-Quart Stand Mixer WSM7Q



Specifications

| Item | Electrical | Listings | Dimensions (H" x W" x D") | Warranty |
|-------|----------------|-------------|------------------------------|------------------|
| WSM7Q | 120 VAC, 60 Hz | cETLus, NSF | 15" x 12" x 16" | Limited Two Year |

Ordering Information

| Description | Catalog # | Std Pkg. | Ship Wt. (Lbs.) | Cubic Feet | UPC Code |
|--|-----------|----------|--------------------|------------|--------------|
| Professional 7-Quart Commercial Stand Mixer | WSM7Q | 1 | 25 | 3.3 | 040072008177 |

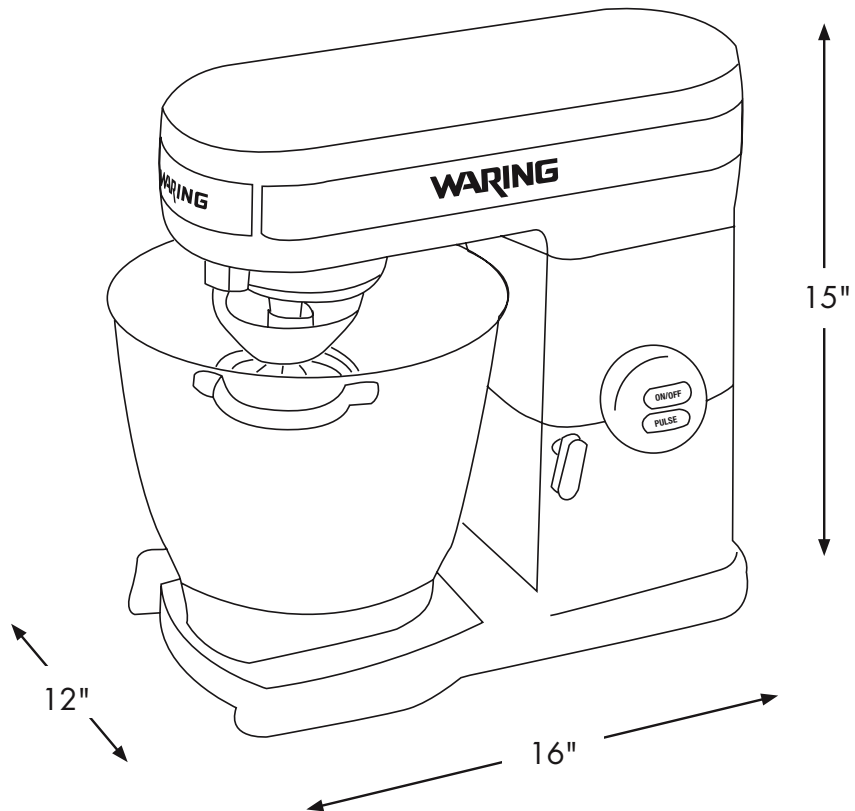

Waring Commercial • 314 Ella T. Grasso Ave. • Torrington • Connecticut 06790
Tel. (800) 492-7464 • Fax (860) 496-9008 • www.waringproducts.com • ©2007 Waring