

F-686 BUILT-IN FRYER

F-686 BUILT-IN FRYER



Wells F-686 Built-in Autolift Fryer is one of the most durable and versatile fryers in the industry. Swing-up elements allow the fry pots to be easily removed for cleaning, while the elements' low-watt density provides extended oil life. Fry two separate foods at the same time using the individual fry pots.

Features

- **The autolift fryer** has an adjustable one to fifteen minute push-button timer for each fry pot that automatically lifts the basket from oil.
- **Swing-up elements**, located below the baskets, allow easy removal of the fry pots for cleaning. Elements are heavy-duty stainless steel with low watt density for longer oil life.
- **Element control housings** have a spring-loaded support rod to secure elements when in a raised position.
- **Timer controls** are recessed in a one-piece, drawn, remote stainless steel panel.
- **Positive-off thermostats** control the elements, allowing for adjustable and more consistent temperatures. Signal lights indicate that the heating elements are energized.
- **Deep-drawn, removable fry pots** are made of nickel-plated steel and can hold up to fifteen pounds of oil each.
- **A manual reset safety thermostat** will shut off the heating element power and illuminate the signal light if an over-temperature condition is reached.
- **A terminal block** is provided for field wiring connection to the main power supply.
- **Two full size, rear-hanging, interchangeable fry baskets** are provided and allow for product versatility.
- **Wellslok** allows for quick and easy installation in stainless steel countertops.
- The F-686 Fryer is **Underwriters Laboratories, Inc. recognized** and meets NSF International standards.
- **A one-year warranty** against defects covers parts and labor.

Specifications

Overall Dimensions:		Inches	MM
Width	24 13/16	630	
Depth	23 9/16	598	
Oil Capacity:		Lbs.	KG
F-686	30	14	
Temperature Range:		Fahrenheit	Celsius
F-686	275° to 375°	135° to 191°	
Pre-Heat Time to 350° F:		5 minutes	
Watts Per Hour to Maintain 350° F:		445	
Typical Production:		Per Hour	
French Fries (2 oz. servings)	480		
Chicken (pounds)	32		
Weights:		Lbs.	KG
Installed	71	32	
Shipping	82	37	

Accessories / Options

- Basket**, half-size (2 per fry pot), 20161
- Basket**, full-size (1 per fry pot), 20162
- Crumb Cradle**, 20690
- Fry Pot**, replacement, 20169
- Fry Pot Cover**, 21010





DIMENSIONS: INCH
 (MM)

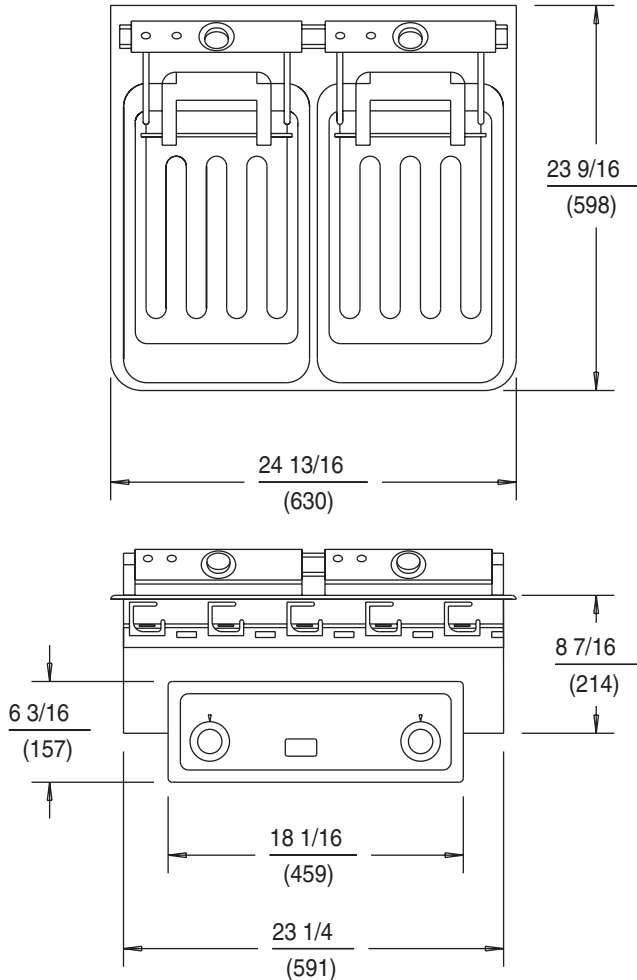

SUGGESTED CLEARANCE FROM UNIT TO THE NEAREST SURFACE			
BACK	SIDE	BOTTOM	FRONT
$2 \frac{1}{4}$ (57)	3 (76)	6 (152)	3 (76)

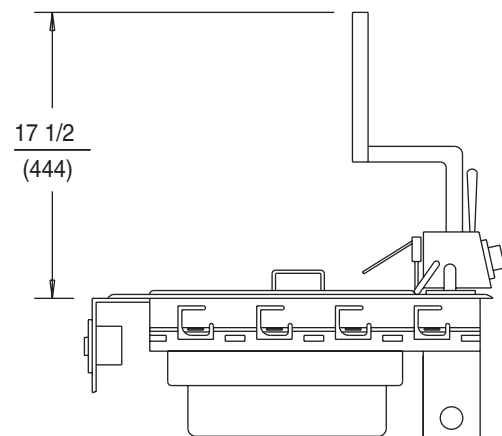

F-686 ELECTRICAL SPECIFICATIONS:

MODELS	VOLTS	WATTS	AMPS PER LINE 3 PHASE			AMPS SINGLE PHASE	POWER SUPPLY CORD
			L1	L2	L3		
F-686	208	9200	38.3	22.1	22.1	44.2	NONE
F-686	240	9200	33.2	19.2	19.2	38.3	NONE

NOTE: Specifications are subject to change without notice. See installation instructions prior to installing the unit. This document is not for installation purposes. The installation of recognized component units requires additional evaluations to Underwriters Laboratories Inc. standards. Depending on the installation, clearances can be changed upon further evaluations to UL standards.

THIS UNIT IS DESIGNED TO BE INSTALLED IN METAL COUNTERS ONLY

WELLS MANUFACTURING COMPANY
 2 ERIK CIRCLE, PO BOX 280, VERDI, NV 89439 U.S.A.
 USA PHONE: (775) 689-5700 • FAX: (775) 689-5972
 FOR ORDERS ONLY: (888) 356-5362 • FAX: (800) 356-5142
 www.wells-mfg.com
 © 2002 WELLS MANUFACTURING • PRINTED IN THE U.S.A.
 03/02 • REV(J) • PART NO. 37105

