

# HW/SMP-6D RECTANGULAR COOK 'N HOLD WARMER

HW/SMP-6D RECTANGULAR COOK 'N HOLD WARMER



HW/SMP-6D

## Specifications

<b>Overall Dimensions:</b>	<b>Inches</b>	<b>MM</b>
Width	14 3/4	375
Depth	23 1/2	597
<b>Temperature Range:</b>	<b>Fahrenheit</b>	<b>Celsius</b>
HW/SMP-6D	90° to 210°	32° to 99°
<b>Number of Thermostats:</b>	1	
<b>Weights:</b>	<b>Lbs.</b>	<b>KG</b>
Installed	23	10
Shipping	26	12

Wells HW/SMP-6D Built-In Cook 'N Hold Warmer is designed for efficiency. The tubular immersion element allows for rapid heat transfer into the water. Wells Cook 'N Hold Warmers quickly heat food from a refrigerated state to serving temperature.

## Features

- **The tubular element**, located inside the well, is controlled by a positive-off thermostat and allows for quicker heating.
- **The positive-off thermostat** is recessed in a one-piece, drawn, front-mounted panel.
- **Warming pan is deep-drawn, stainless steel** for maximum strength and durability and has a 1/2" drain.
- **Wellslok** provides quick and easy installation in stainless steel countertops.
- This warmer is designed for **wet operation only**.
- **The HW/SMP-6D Cook 'N Hold Warmer** is Underwriters Laboratories, Inc. LISTED and meets NSF International standards.
- **A one-year warranty** against defects covers parts and labor.

## Accessories / Options

**Adapter Top**, to convert HW/SMP-6D to hold three 4-quart insets, 21615

**Adapter Top**, to convert HW/SMP-6D to hold one 7-quart inset and one 4-quart inset, 21617

**Adapter Top**, to convert HW/SMP-6D to hold one 7-quart and one 11-quart inset, 21621

**Adapter Top**, to convert HW/SMP-6D to hold four 2 1/2-quart insets, 21624

**Inset**, 2 1/2-quart capacity with lid, 20773

**Inset**, 4-quart capacity with lid, 20774

**Inset**, 7-quart capacity with lid, 20587

**Inset**, 11-quart capacity with lid, 20908

**Wellslok Extension Kit**, designed for countertops up to 1 1/2" thick, refer to installation instructions, 22593





**MODEL  
HW/SMP-6D RECTANGULAR  
COOK 'N HOLD WARMER**

**DIMENSIONS:**

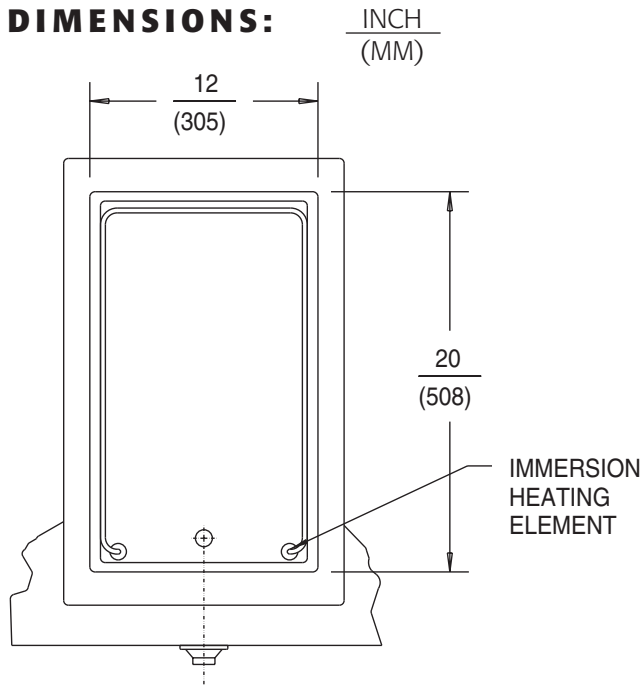

MINIMUM CLEARANCE REQUIRED UNIT TO NEAREST SURFACE			
BACK $\frac{1}{1}$ (25)	SIDE $\frac{1}{1}$ (25)	BOTTOM $\frac{6 \frac{3}{4}}{1}$ (171)	FRONT $\frac{4 \frac{1}{8}}{1}$ (105)

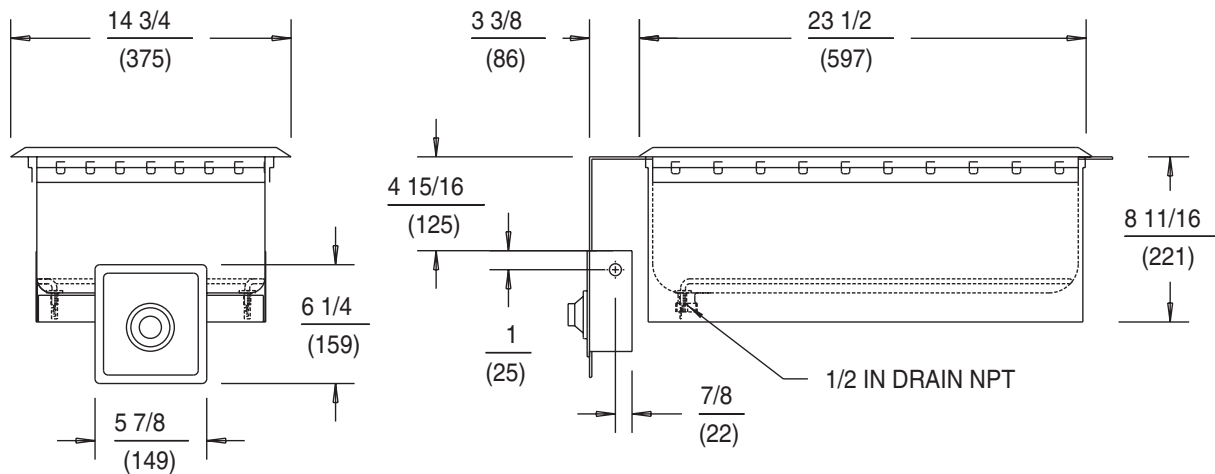

**HW/SMP-6D ELECTRICAL SPECIFICATIONS:**

MODELS	VOLTS	WATTS	AMPS	PHASE	POWER SUPPLY CORD
HW/SMP-6D	208	1350	6.5	SINGLE	NONE
HW/SMP-6D	240	1800	7.5	SINGLE	NONE

NOTE: Specifications are subject to change without notice. See installation instructions prior to installing the unit. This document is not for installation purposes.

